



Summerland

Planning Advisory Committee

SunPAC Meeting #6

March 31, 2008

SunPAC Meeting Agenda

Call to Order

Item 1: Pledge of allegiance and roll call

Item 2: Public comment period

Item 3: Meeting Minutes

- March 19, 2008

Item 4: Continued Review and Discussion of Draft Commercial Design Guidelines



Public Comment

- Please complete a speaker slip



Meeting Minutes

- Review and Approval Meeting Minutes
 - March 19, 2008



March 19th Questions

- *“Sunset Clause” for signage?*
 - Legal Counsel Background
 - A Sunset Clause would address nonconformance through the amortization period provided for in the County’s LUDC (Section 35.38.120)
 - An amortization period to abate nonconformance is not an option for freestanding pole signs like the Liquor sign and Big Yellow sign as they are protected under Business and Professions Code section 5499
- *If an applicant proposes a remodel, are they required to underground utilities?*
 - No
- *Modifications and Variances*
 - Will be addressed at the end of Phase 3



Draft Design Guidelines

■ Chapter 2 - Block Face Character

□ March 19, 2007

- Recognized development pattern differences between the east and west sides of Valencia Street.
- Establish guidelines to encourage this distinction.

□ Defined Commercial Areas

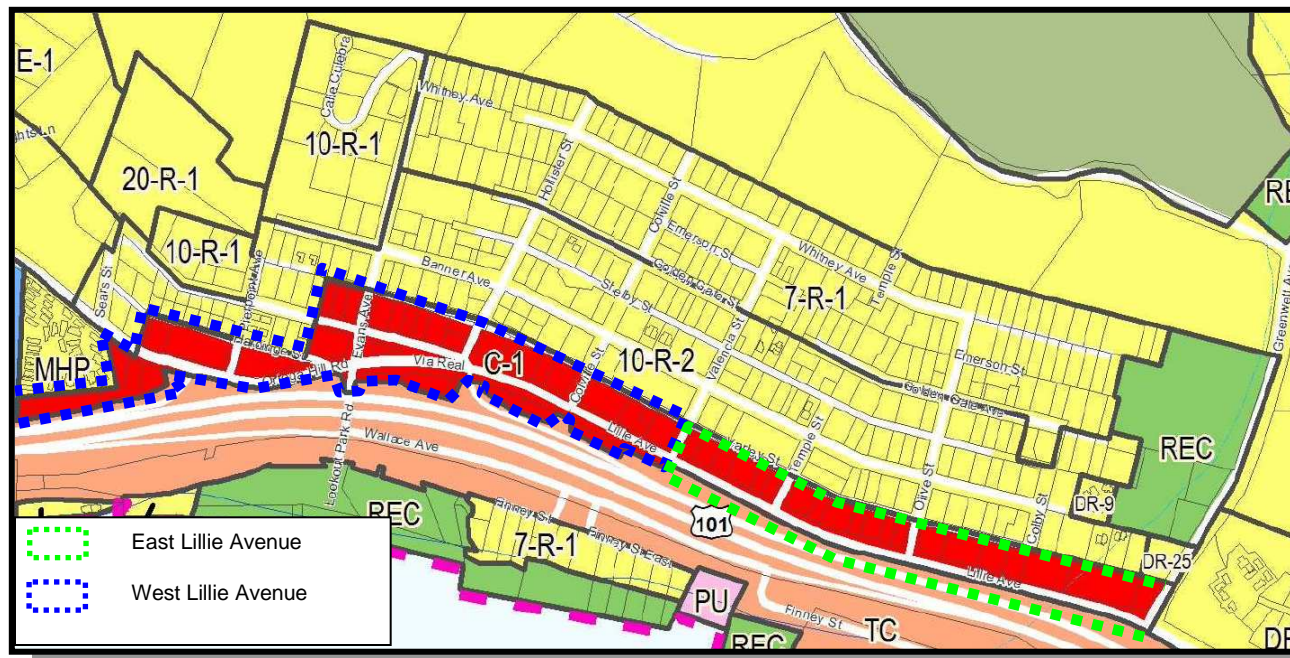

Draft Design Guidelines

■ Chapter 2 - Block Face Character

□ West of Valencia Guidelines

- Bring buildings closer to the street; 5-10 feet.
- Parking required at the rear of the site.
- Requires first floor to be at or near the level of the sidewalk.
- Requires first floor plate to be taller than the second floor plate.
- Encourages widening of sidewalks if possible.
- Establishes minimum fenestration.

□ East of Valencia Guidelines

- Bring buildings closer to the street; 10 feet.
- Encourages first floor to be at or near the level of the sidewalk.
- Encourages first floor plate to be taller than the second floor plate.
- Encourages widening of sidewalks if possible.
- Encourages fenestration.



Draft Design Guidelines

- Chapter 2 - Block Face Character
 - Reference
 - Just Folk Building is approximately 15 feet from the edge of right of way.
 - Kimsey building is approximately 15 feet from the edge of right of way at its narrowest point.
 - East and West Valencia
 - The areas have been delineated.
 - Guidelines have been proposed.
 - Adequacy of proposed design guidelines?
 - Example, require parking in the rear for development east of Valencia
 - Slightly different setback requirements to provide visual relief and character to fit existing development pattern



Draft Design Guidelines

- Chapter 2 - Block Face Character
 - Commercial Area Differentiation
 - SunPAC Direction/Action
 1. Do not distinguish a difference in guidelines between East and West Valencia.
 2. Distinguish a difference in the development pattern between East and West Valencia Street on Lillie Avenue without establishing different guidelines for each.
 3. Establish a difference between East and West Valencia Street and guidelines to reinforce the design of future development (see Attachment 3 for Staff recommendations).



Draft Design Guidelines

- Chapter 3 – Site Design
 - March 19, 2008
 - Recognized Impacts on Varley Street resulting from parking placement.
 - Discuss parking location options
 - Additional traffic and parking information will be provided in Phase III.
 - Question regarding the use of ROW and “front property line” as means of measurement.
 - Generally, there is not a difference.
 - Some parcels in Summerland have granted access easements along Lillie.
 - Public Works has County owns ROW in fee based on original subdivision.



Draft Design Guidelines

■ Chapter 3 – Site Design

□ Existing Setbacks

■ Front Primary

- 30' from road centerline of road or 15' from ROW whichever is greater (an open canopy, porch, or similar structure may extend to within 5' of the ROW)

■ Front Secondary (example: Evans)

- Lot less than 100' wide - 20% of lot width, 10' min.
- Lot 100' or more wide - Same as primary front setback

■ Rear (example: Varley)

- 10% of Lot Depth
- 5' minimum or 10' maximum

□ Proposed Front Setbacks

- If East / West difference is established, 5-10' west of Valencia, 10' east of Valencia

OR

- Should setbacks remain 15' (e.g. Just Folk)?



Draft Design Guidelines

- Chapter 4 – Building Scale and Form
 - Floor Area Ratio (FAR)
 - FAR would remain .29 or .35
 - FAR would remain a requirement
 - Proposed Change: Method of Measurement Consistency
 - Floor Area Ratio
 - Measured to interior of exterior wall

1992 Method

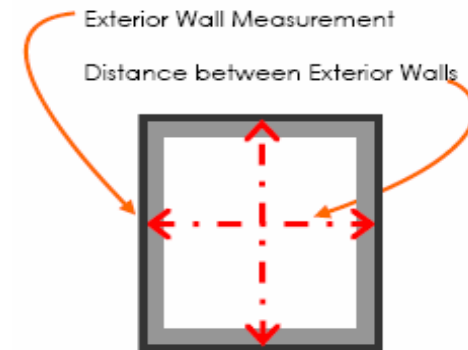

Proposed Method

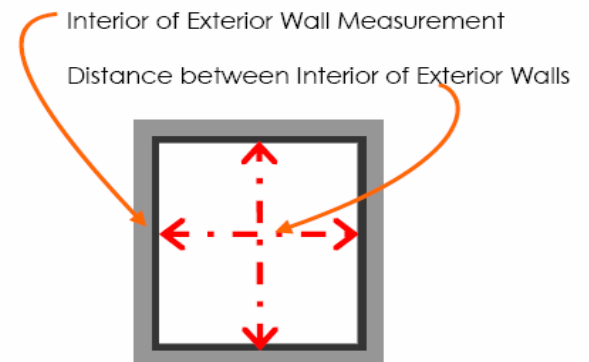

Draft Design Guidelines

- Chapter 4 – Building Scale and Form
 - Floor Area Ratio
 - Existing Buildings, Methodology Change

Table 3 FAR Methodology Comparison Results				
	1992 Calculations	Proposed Calculations	Difference	Percent Change
Just Folk	5,673	5,331	342	6%
Kimsey Building	4,100	3,813	287	7%



Draft Design Guidelines

- Chapter 4 – Building Scale and Form
 - FAR Exclusions
 - Basements
 - “Basement – Summerland: A basement shall be counted as a story if its floor-to-ceiling height is 6.5 feet or more, and the finished floor directly above is more than 4 feet above the finished grade for more than one-half of its perimeter.”
 - Affordable Housing
 -residential units accessory to commercial uses that meets the County's definition of affordable housing and comply with the density requirements for C-1, Limited Commercial Zoning



Draft Design Guidelines

- Chapter 4 – Building Scale and Form
 - FAR Exclusions
 - Affordable Housing as an accessory use
 - Size Limited by LUDC
 - 9,718 SF; Average Lot Size in Summerland

Table 4 Residential Accessory Uses in Commercial Areas					
Lot Size	Size	X	FAR	=	Allowable Floor Area
	10,000		0.35		3,500
Maximum Floor Area allowed for Residential	Commercial Floor Area	X	Maximum % for Residential	=	Residential Floor Area
	3,500		0.49		1,715
Bedrooms Allowed ⁽¹⁾	Commercial Floor Area	÷	1 Bedroom allowed per	=	Total Bedrooms Allowed ⁽²⁾
	3,500		500		7.0
<p>(1) The LUDC allows 2 bedroom per 1,000 square feet of commercial floor area. For the purposes of this table we have simplified the formula.</p> <p>(2) The total number of bedrooms allowed are required to be rounded down. In this case the maximum number of bedroom would be 3.</p>					



Draft Design Guidelines

- Chapter 4 – Building Scale and Form
 - FAR Changes
 - SunPAC Discussion Direction/Action
 - Floor Area, Net
 - Measured to Interior of Exterior Wall
 - Exclude basements as noted
 - Exclude “affordable” housing within a mixed use project.



Draft Design Guidelines

■ Chapter 4 – Building Scale and Form

□ Building Height

■ Proposed Changes

□ Consistency

■ Methodology

- Consistent with Countywide Measurements.
- Maximum Height Remains 22'.
- Building and roof must be under height envelope.



Draft Design Guidelines

■ Chapter 4 – Building Scale and Form

□ Building Height

■ Comparison

□ Existing

- Measured to mean of roof
- Average of all sides
 - Allows height to exceed 22' from grade and large wall expanses.

□ Proposed

- Measured to highest point of structure
- Maintains height within 22' envelope
- Encourages structures to be pushed into the slope and to reflect the existing topography



Draft Design Guidelines

- Chapter 4 – Building Scale and Form
 - Building Height
 - Proposed Changes
 - Methodology

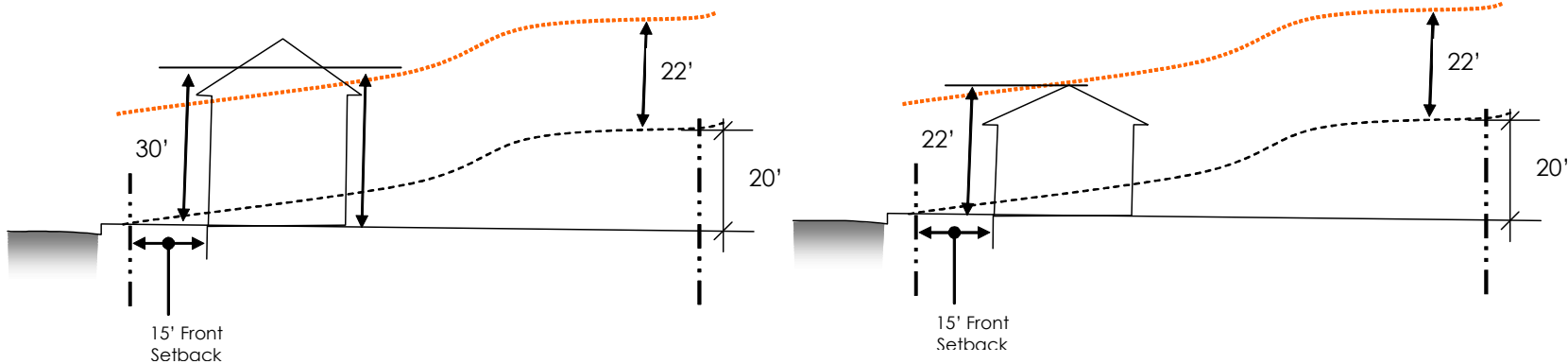

Draft Design Guidelines

- Chapter 4 – Building Scale and Form
 - SunPAC Discussion
 - SunPAC Direction/Action
 - Height Methodology
 1. Retain Existing Methodology.
 2. Adopt County Wide Methodology as proposed.
 3. Tentatively adopt County Wide Methodology as proposed, pending Residential Guidelines review and discussion.



Draft Design Guidelines

■ Chapter 5 – 9

□ See Attachment 6 for review of SunPAC Feedback and Comments

■ Issues identified for possible further SunPAC discussion:

□ Chapter 6 – Building Details:

■ Should change of paint color require BAR review?

□ Other issues?



Next Meeting

- Finalize Draft Commercial Design Guidelines:
 - Wednesday, April 30, 2008
 - A revised Draft Commercial Design Guidelines document will be issued prior to this meeting
 - Review and conclude any outstanding issues
 - If any chapters are not concluded at this meeting, a SunPAC sub-committee will be appointed to finalize Draft Commercial Design Guidelines
- Residential Design Guidelines Introduction and Background:
 - Wednesday, May 7, 2008

